



DODA U.S.A. INC.
255 16TH ST. SOUTH
ST. JAMES, MN 56081
P: 507.375.5577 F: 507.375.5578
www.doda.com admin@dodausa.com

USE AND MAINTENANCE MANUAL AFI CHOPPER PUMPS



All rights reserved, copyright of this manual only under license from DODA Inc.

Data and measures written in this manual are approximate and there may be some changes without warning.



DODA thanks you for buying an item in its production and invites you to read this use and maintenance manual.

You will find within the manual information necessary for correct use and maintenance of the machine you have purchased so please carefully follow the directions.

Please also keep this manual in a safe place for future reference.

The content of this manual may be changed without notice in order to make changes or improvements to units already sold.

No reproduction or translation of any part of the manual is admitted unless authorized.

DESCRIPTION	PAGE
Introduction	1
Machine loading and unloading	2
General remarks	3
Preliminary checks	4
Positioning and Transportation	5
Working	6
Work and Safety Rules	7
Maintenance	8
Changing Oil	9-10
Stickers	11
Performance and Technical Data	12
Optionals	13
Instructions for dismantling and re-assembling the pump	14
Instructions for dismantling and re-assembling the pulley	15
Parts View's	16-27

The machine described in the following manual is a pump made to treat thick animal excrement or working residue of industrial plants which are too dense to be easily pumped out. These thick residues present in liquid manure are transported by means of a double chopper.

Thanks to AFI pumps, liquid manure can be:

- taken and brought to the collecting tank;
- conveyed to the pipes of the fertilization/irrigation systems;
- loaded on tank-trucks for transportation.

In order to eliminate leaks of treated substance, AFI pumps are fitted with Widia mechanical seals instead of packing or stuffing boxes. This method improves the pump performance and decreases priming times.

Manufactured in various models, with varied performance and power absorption, they are supplied in the following versions: with PTO shaft, powered by electric motors or hydraulic engines.

From the technological point of view, the concept adopted for all other DODA products has been applied to this machine:

“Highest quality to obtain the maximum reliability and durability.”

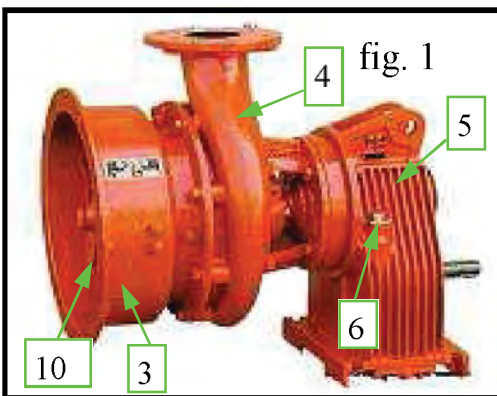

The model illustrated in fig. 1 is equipped with PTO drive. The gear ratio is indicated on the plate on the gearbox. The pump is available in different models & ratios with or without trailer.

Fig. 2 shows the same model powered by an electric motor. The plate on it reports the type of connection and voltage. This pump is also supplied in various models with or without trailer.

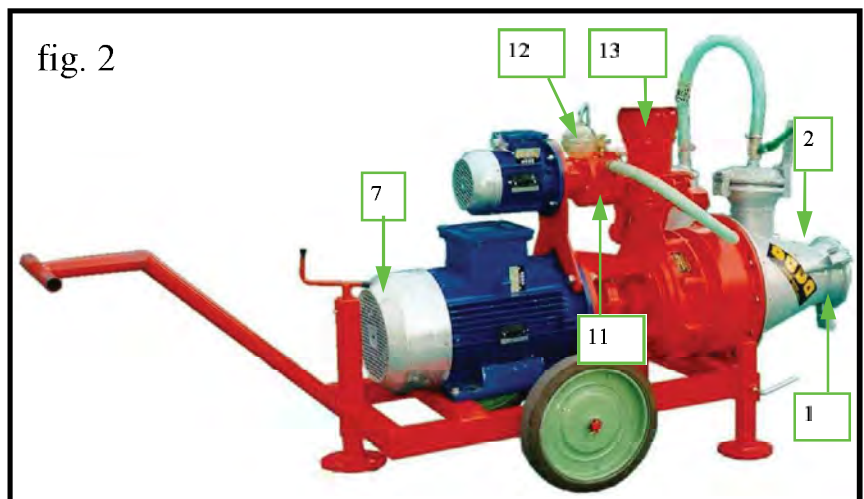
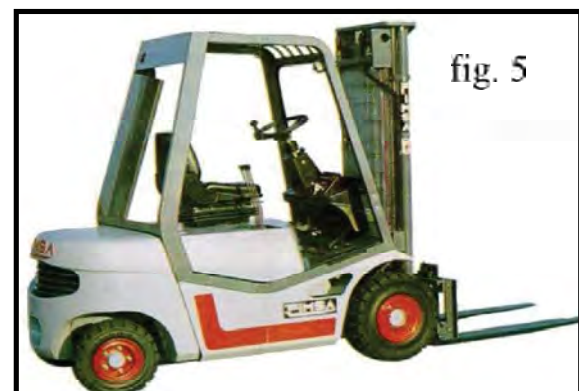
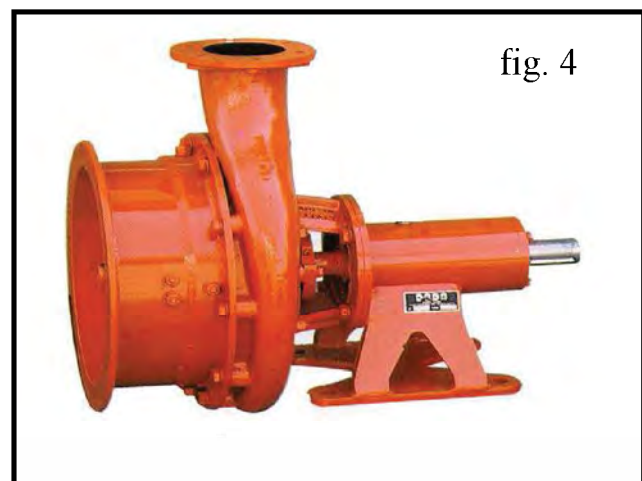
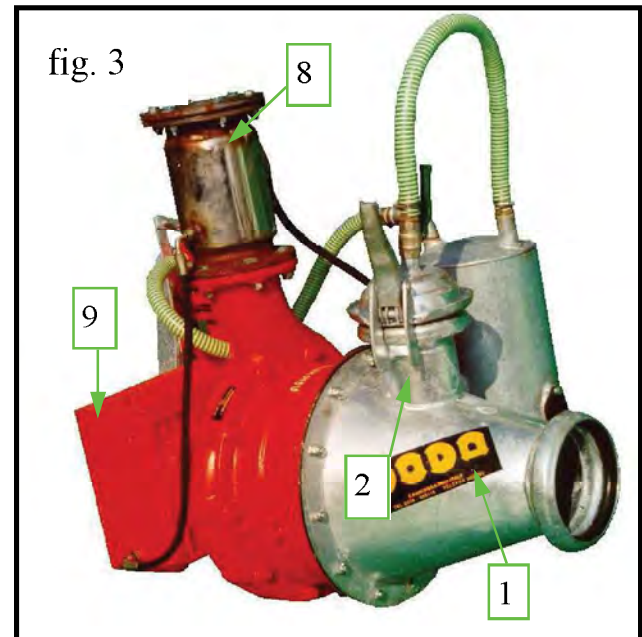

Fig. 3 shows a version with a “IV” unit for connecting to internal combustion engines (Diesel engines are most suitable), which allows to utilize a lower RPM. This system multiplies the impeller speed compared to the engine. This version is provided with an oil-cooling system.

Fig. 4 shows a pedestal mount (direct drive) unit. These can be mounted directly to an Electric motor or Diesel engine.

- 1) Intake cone
- 2) Plug to fill priming
- 3) Conveyor
- 4) Pump body
- 5) Drive box
- 6) Oil level plug
- 7) Electric motor
- 8) Cooling system for AFI with “IV” gear box.
- 9) “IV” gear box
- 10) Chopper blade
- 11) Vacuum pump
- 12) Vacuum pump oil tank
- 13) Delivery



2. MACHINE LOADING AND UNLOADING

The machine loading and unloading operation can be carried out:

- by means of a lift truck;
- by means of a hoisting crane.

Make sure the carrying sling is sufficient to lift the pump



WARNING: in either case the machine must not be lifted by catching on the weakest parts of the structure (delivery pipes, etc...).

WARNING : before lifting the structure, be sure that it is well-balanced.

WARNING: never move abruptly or bump stainless steel parts with the forks of the lift truck.

3. GENERAL WARNING

- 1) Check that no component has undergone damages during transportation. If damages have occurred, call your dealer immediately.
- 2) The connection to power supply must be carried out according to DODA instructions, by specialized staff. DODA is in no way responsible for any electric connection.
- 3) Before starting the machine check that the rotary driving parts are adequately protected, as foreseen by their manufacturer.
- 4) If the protection of a rotary part is not an issue, it must be carried out by the operator in conformity with prevailing law.
- 5) DODA takes no responsibility for modifications altering the characteristics of the machine.
- 6) Before operating the machine it is important to carefully read all directions in the **“Instructions for use and Maintenance”** manual. Be sure that you completely understand the machine operation. If not contact you dealer for clarification.
- 7) The machine has been designed and built to treat water and sewage, not for chemical products. Handling these substances can cause permanent damage to this machine.
- 8) Check that the machine length is adequate to the depth of the tank.
- 9) In regards machines with oil-bath driving, the driving pipe as well as the gearbox (if present) must be filled with oil.
- 10) Carefully avoid that machine rubber parts do not come into contact with oil, grease or other oil derivatives.
- 11) The pump must never operate with no-load (see “OPERATION”).



4. PRELIMINARY CHECKS

Our machines may be supplied without oil either in the driveline or in the gearbox. Before starting the machine, check oil levels and fill if necessary.

- unscrew caps: in driveline, gearbox or pedestal
- Pour 80/90w in drivelines, in gearbox use 85/140w check oil level!
- fill with high-temperature 75/90W synthetic oil (AFI REVERSE GEAR & HD)
- wait at least 30 minutes then check the oil level and add more oil if necessary
- close caps.
- Check the oil level periodically

If the machine is provided with a vacuum pump 11 fig. 2 the tank of the latter must be filled 12 fig. 2 with fluid (hydraulic) oil for blade lubrication.

INDICATIVE OIL QUANTITY LEVELS FOR DRIVING PIPE

Gearbox	AFI L 20	AFI L 24	AFI L 27	AFI L 35
Oil quantity (L)	1	4	4	4

AFI with gearbox HD	Including cooling system
Oil quantity (L)	12

AFI with gearbox IV	Including cooling system
Oil quantity (L)	16

AFI PD with direct drive	Including cooling system
Oil quantity (L)	.8

5. POSITIONING AND TRANSPORTATION

As far as all machines with PTO shaft are concerned, connect the PTO shaft between the tractor power take-off and machine unit. For good functioning, the PTO shaft must operate on ground level.

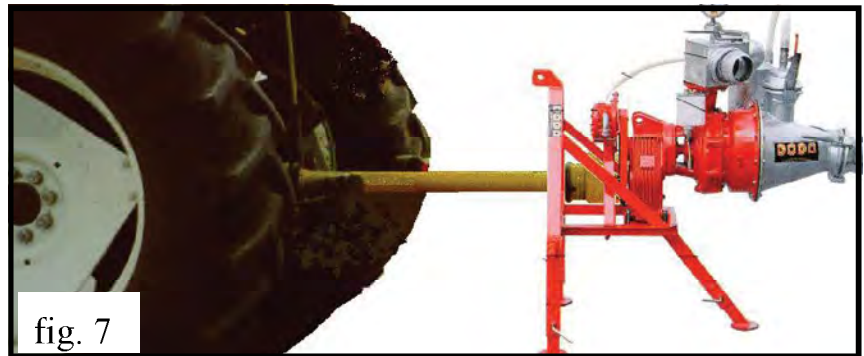

fig. 7

Also check that the chain, for PTO shaft protection is fastened to the ring.

For machines powered by electric motor, Doda is not responsible for any electric connection. Please carefully follow directions on motor tags as well as on any tags or stickers on pump.

When transporting the machine make sure it is loaded and tied down properly. Never use a tractor for transporting the machine over long distances.

The AFI pumps should be placed very close to the area where you want to start intake. Connect the intake pipe as well as the delivery pipe according to your needs. Thanks to high pressure exerted by these pumps, it is possible to transport the material taken in over long distances or to directly connect an irrigation flow to the delivery pipe.

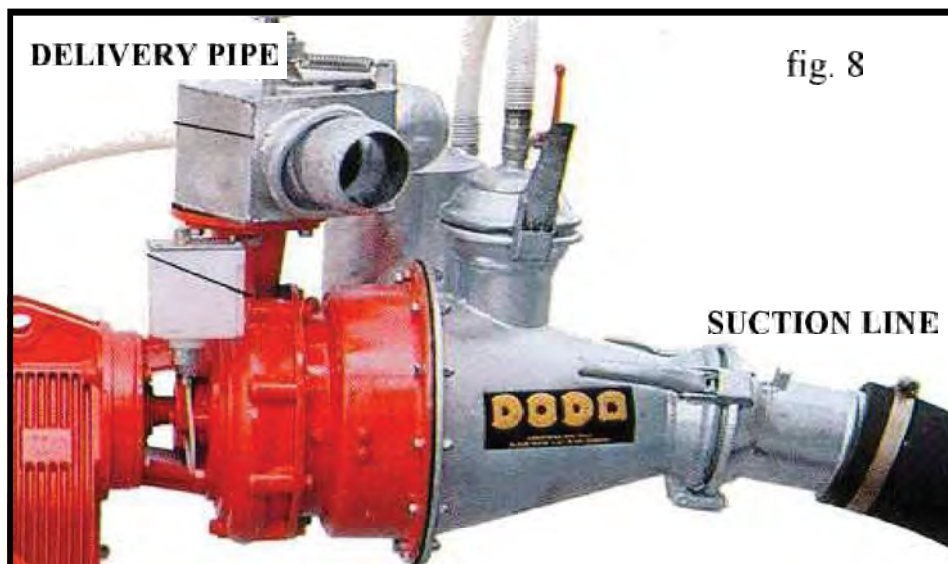

fig. 8

6. WORKING

WARNING: read section "GENERAL INSTRUCTIONS" before starting the machine. After arranging the machine and checking its stability during normal functioning you can start utilizing it.

Starting phases:

- start tractor;
- fill intake cone with water or liquid manure through the special opening 2 fig. 3. Use vacuum pump for quicker priming (See section "OPTIONALS" pg. 11);
- operate the lever engaging tractor's power take-off;
- bring tractor to a high speed ratio until pump is engaged (priming time varies in function of tank depth and density of material taken in);
- bring tractor to the desired speed ratio again.

Stop phases:

- disconnect lever engaging tractor's power take-off;
- stop tractor's engine;
- disengage PTO shaft both on tractor and on pump side;
- disconnect intake pipe from cone to let out the residual material;
- open the valve inside the cone (use a pipe) to let out the manure which is still inside the pump.

As for all models with an electric motor, after checking the correct rotation direction, connect them to power supply.

WARNING: be sure that the system is not under pressure before opening delivery pipe.

WARNING: never operate the pump NO-LOAD, without filling the cone 1 fig. 3 through the special filling opening (cap) 2 fig. 3

If the difference in level to overcome, between the fluid surface and the intake cone, is higher than 10' the bottom valve should be used (see cap. "OPTIONALS")

- 1) During machine inspections, while operating as well as during inspection phases, always wear proper clothing (overalls, gloves, helmet, proper footwear etc.)
- 2) The machine must always be used where well lit.
- 3) Since gases released by liquid manure are poisonous, check that:
 - the work area is adequately ventilated;
 - the machine is not operated in proximity to flames.
- 4) Never inspect the liquid manure tank alone. You could loose your balance or become faint due to fumes.
- 5) If you do not need to work in a tank, keep it covered.
- 6) The machine must be operated by accountable adults, while the place must not be accessible to children.
- 7) Do not carry out operations or regulations when the machine is in motion or when it is connected to supply.
- 8) The machine must only be employed with all protections correctly positioned, following instructions indicated in the previous paragraphs to avoid possible contact with moving parts. Do not alter or remove those protections.
- 9) The machine must never be operated without having filled oil-tank (driving pipes and geared units).
- 10) Before starting work phases, be sure that the whole assembly is stable (machine and tractor).
- 11) During maintenance be sure that the machine is stable and disconnected from power supply.
- 12) During operation, maintenance or regulation, avoid contact of machine rubber parts (gaskets, etc...) with oil, grease or oil derivatives.
- 13) Be sure that **MOTOR ROTATION IS CLOCKWISE** as indicated by the arrow on the motor (when engaged)
- 14) For electrical operated machines, connection should be in a place protected from weather elements.
- 15) If delivery pipe is connected to pipes or hoses, check that any fastening joints are in proper working condition and are not at risk of bursting or tearing.
- 16) Keep the machine in a dry area, protected from weather elements. Especially when not used for long periods of time.
- 17) The machine must **NEVER be operated with No-Load.**

Before carrying out any maintenance operation, stop the machine and disconnect it from power supply.

- 1) Check the oil level regularly and machine parts requiring lubrication, (drive pipes and gear boxes) and replace oil completely after the first 50 working hours and every 1500 working hours or every year. In the gearbox use 85/140w oil.
- 2) Grease rotary parts every 50 working hours (grease zerks, joints, gear wheels etc.)
- 3) At the end of its utilization, wash the machine to prevent liquid manure from solidifying: this will cause premature wear & damage to working parts of the pump.
- 4) Check for wear on blades and impeller periodically and replace when necessary.

For spare parts contact your DODA dealer directly.

ATTENTION!

When the machine is new we advise to change the oil after the first 50 working hours.

After the first oil change it is advised to change oil once per year or every 1500 hours.

Oil change instructions on page 9 & 10



Unscrew oil breather plug 'A' (fig. 10)

Remove the plug 'B' to drain the oil (fig. 10)

To speed up the oil draining out of the gearbox it is best to do it while gearbox is still warm.

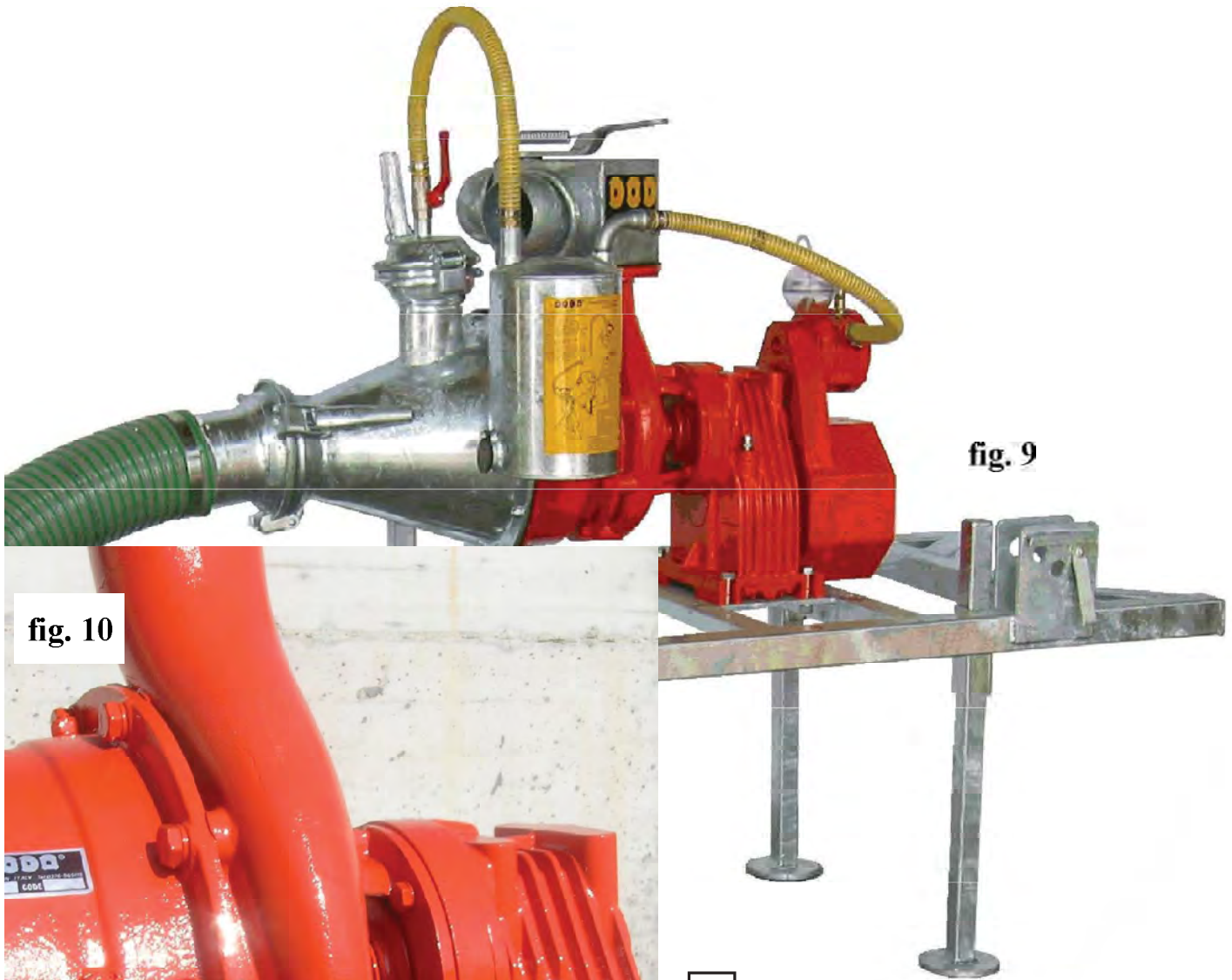

fig. 9



fig. 10

A

B

OIL CHANGE:

Replace plug 'B' on (fig. 10)

Remove the cap 'A' (fig. 11) fill with new oil

Check the oil level on plug dipstick 'B' (fig. 11) before starting the machine.

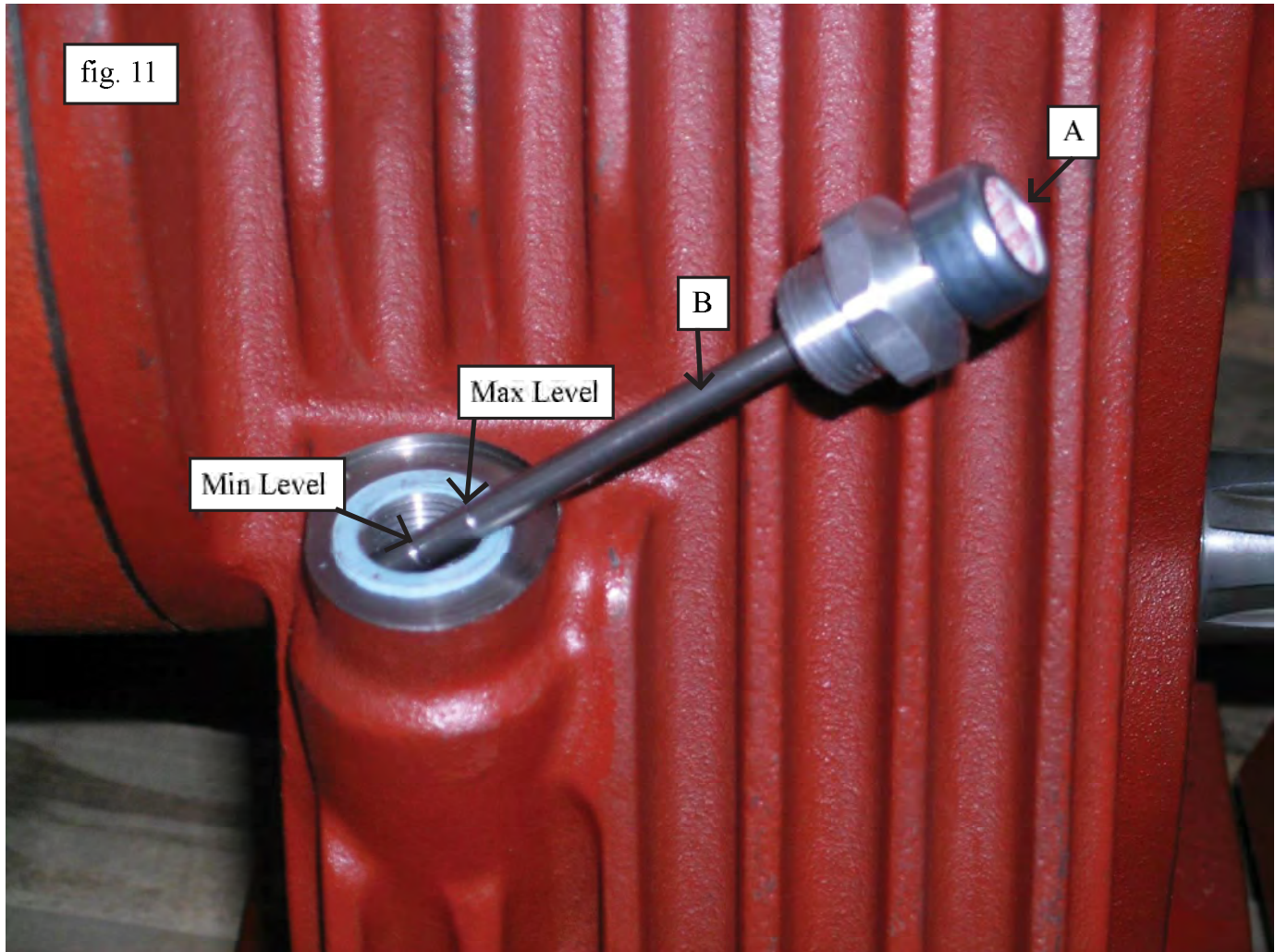

WARNING!

Make sure to check oil level often to avoid gearbox overheating

Oil quantity needed approx : ~ 3.5 lt

The machine is provided with the following stickers:

DODA U.S.A. INC. St. James, MN
www.doda.com

- Fill the cone by pouring liquid into it (A)
- Seal the cap so it is air tight
- Start the pump by setting the PTO in action
- Move lever 'B' to position '2'
- Move lever 'C' to position '2' and hold it there until you see the first drops of liquid moving through the hose that connects the cap and the canister
- Move lever 'B' and 'C' back to position '1'

The pump is now primed.

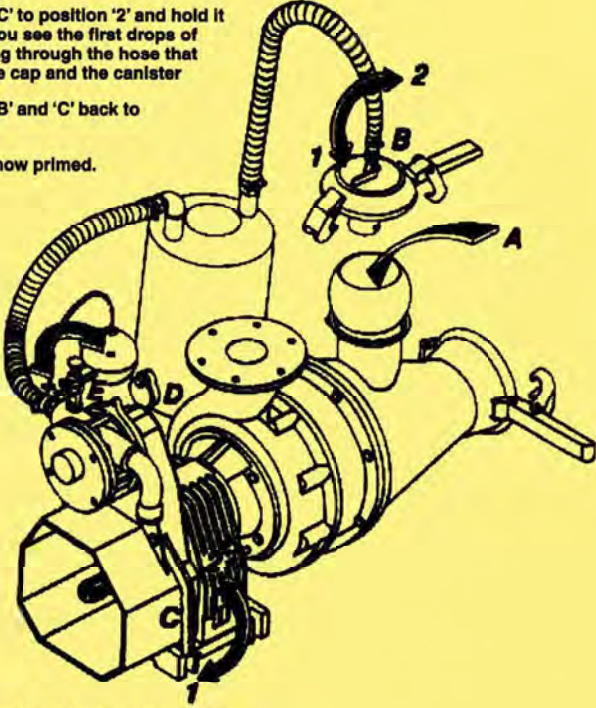

IMPORTANT!
If the pump does not prime after these steps you must check that all connections and hoses are perfectly sealed with no air leaks. Also the rubber flap 'D' must stay in the indicated position. Keep the oiler 'E' open to allow for best performance of the primer.

Pour fluid into the cone until it is full 'A'.

Close cap tightly.

Start pump by operating tractor's power take-off .

Move lever 'B' to '2'.

Shift lever 'C' to '2' and keep it in that position until the first fluid drops go up the pipe connecting the cap to the cleaner.

Shift lever 'B' and 'C' to '1'.

WARNING

If, once these operations have been completed, the pump still does not work, check the seal of the pipes, hoses, gaskets and make sure that gasket 'D' (rubber flap on canister) is in position shown. Also be sure brass oil dripper 'E' is open to allow for best performance of the primer.

The following add-ons, all manufactured by DODA can be applied to all AFI pumps.

TEE MANIFOLD: Mounts on the AFI discharge flange. Can have 4", 6" discharge or block one side off with a plate. Brass valves allow for shutoff of flow.



fig. 9

TWO-WAY VALVE: located at pump output, it allows to select two different deliveries by means of a manual or automatic lever. This method is resorted to if one of the two output is utilised to mix the product or to serve two different lines. **Before starting the lever - during operation - minimize the pump revolution number.**



fig. 10

VACUUM PUMP: it is used for a quicker and safer priming. Instructions for using this system are located on the sticker on the canister.



fig. 11

12. INSTRUCTIONS FOR DISMANTLING AND RE-ASSEMBLING THE PUMP

To dismantle the pump body follow the numerical progression as shown in the parts view. Dismantle fixed blades (1) first and other components afterward. The rotating chopper blade (2) spins off counter clockwise.

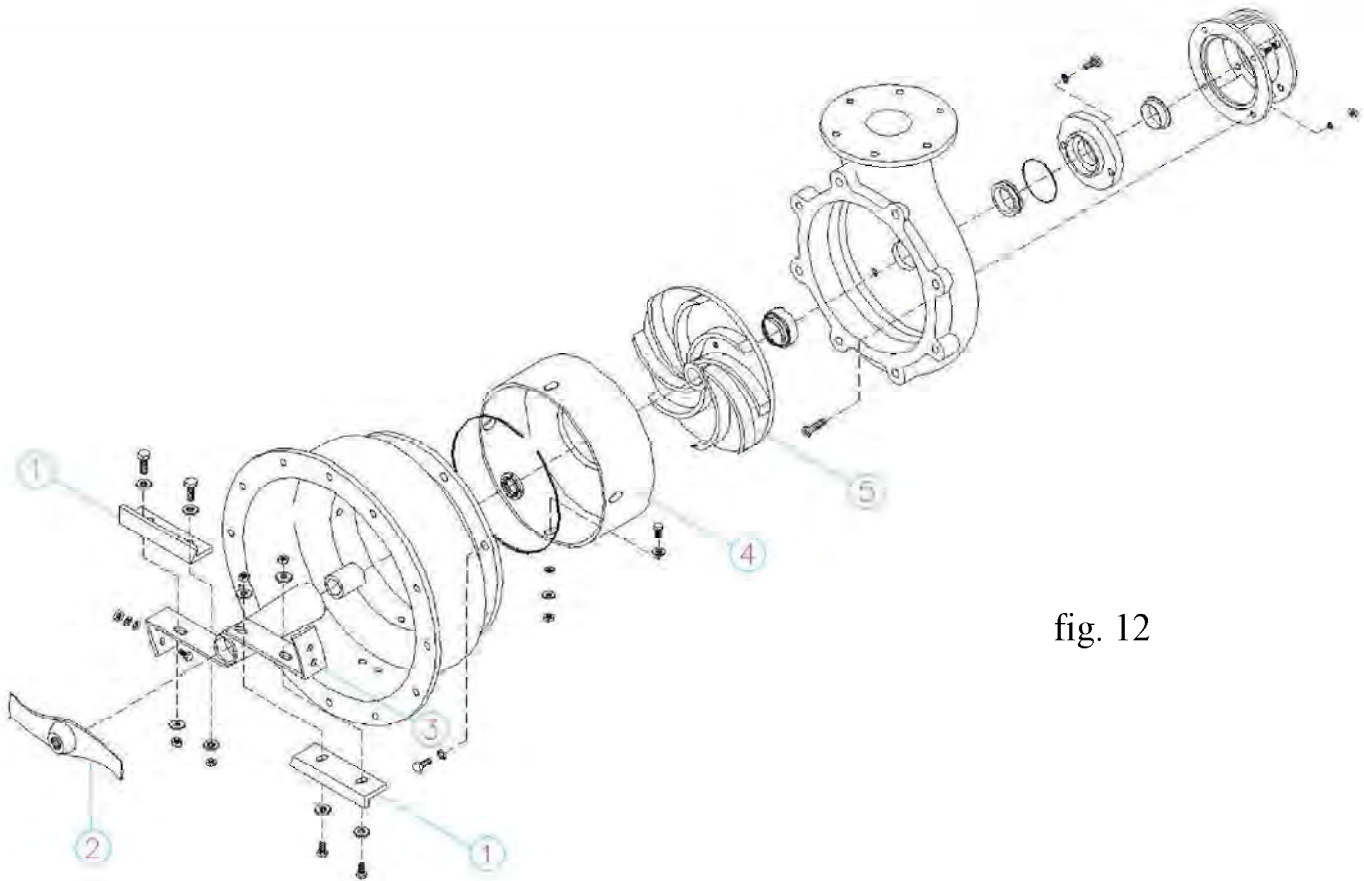

fig. 12

In order to remove the impeller, screw two bolts into the hole 'A' shown in the picture, until the complete ejection of the impeller itself.

The counter-impeller 'B' (pressure plate) must be re-assembled with the wider part toward body outlet (as shown in figure 13)

When assembled, the reverse-impeller should skim the impeller vanes, sit as close as possible without touching (thickness of credit card)

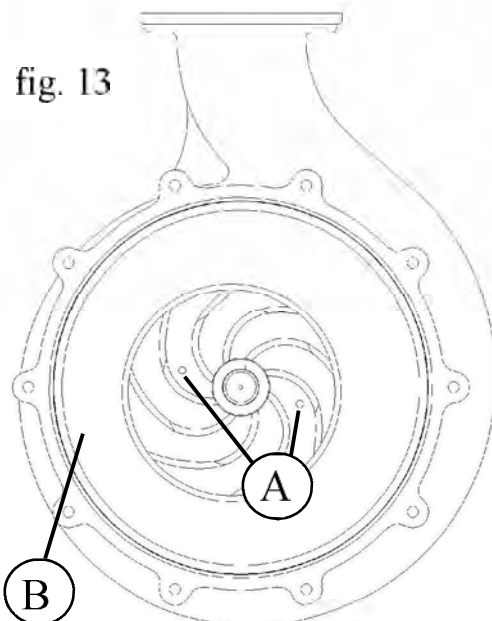
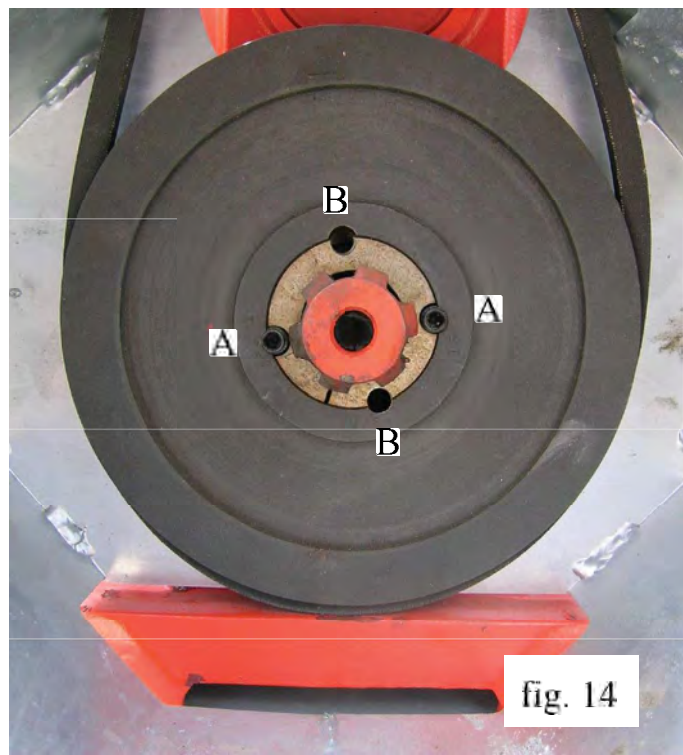

fig. 13

13. INSTRUCTIONS FOR DISMANTLING AND RE-ASSEMBLING PULLEY

Unscrew two bolts 'A' (see figure 14) and screw the bolts into hole 'B' to loosen the pulley from the shaft.

For re-assembling: fit two bolts into the original position 'A', place the pulley on the shaft and push all the way to the back. Tighten the bolts until pulley will not move when pulled towards you.



Parts descriptions for AFI 35 Housing. Call your dealer for pricing.

E2003K	AFI 35 HOUSING PARTS VIEW
1204	BUSHING, BRONZE FOR STATIONARY SUPPORT
1502	BLADE, STATIONARY AFI & ME120
2907	COVER, AFI WIDIA SEAL
2932	SUPPORT, STATIONARY CUTTER BLADE, AFI (INCLUDE ITEM 1204)
2940	BLADE, CHOPPER AFI AND 7.5-15HP ME 100-120
3000	HOUSING, AFI 35 PUMP
3001	ADAPTER, TRANSITION
3002	PRESSURE PLATE, AFI 35 (13.875" DIA)
3003	IMPELLER, AFI 35 (350MM 13.75")
3034	AFI GEAR BOX SUPPORT
BUL5151	NUT, M10 NY-LOCK, ZINC
BUL5163	BOLT, M10X35 ZINC
BUL5250	NUT, M14 ZINC
BUL5261	BOLT, M 14X30
BUL5261	BOLT, M14X30
BUL5896	BOLT, M14X40 FHSCS
BUL5952	WASHER, FLAT M10 ZINC
BUL5964	WASHER, M10 ALUMINUM
BUL5982	WASHER, M10 LOCK, ZINC
BUL5984	WASHER, M14 LOCK
BUL7002	NUT, IMPELLER LOCK 35X1.5
BUL7536	SCREW, SET M10 S.S.
GTP117	SEAL, RUBBER WASHER H150
GTP125	SEAL, WIDIA STATIONARY, AFI PUMP
GTP126	SEAL, WIDIA ROTATING, AFI PUMP
GTP127	O-RING, OIL FOR WIDIA SEAL HOLDER D.66, 35 S.2.62
GTP133	O-RING, AFI 35 GB41300
GTP194	O-RING FOR AFI WIDIA SEAL (GTP126)
GTP263V	O-RNG FOR AFI WIDIA SEAL (GTP125)
RAC102	PIPE CAP, ZINC 1/2"

Parts descriptions for AFI 27 Housing. Call your dealer for pricing.

E2002K	AFI 27 HOUSING PARTS VIEW
1204	BUSHING, BRONZE FOR STATIONARY SUPPORT
1502	BLADE, STATIONARY AFI & ME120
2907	COVER, AFI WIDIA SEAL
2932	SUPPORT, STATIONARY CUTTER BLADE, AFI (INCLUDE ITEM 1204)
2940	BLADE, CHOPPER AFI AND 7.5-15HP ME 100-120
2975	HOUSING, AFI 27 PUMP
2976	ADAPTER, TRANSITION AFI27
2977	PRESSURE PLATE, AFI 27 (10.25" DIA.)
2978	IMPELLER, AFI 27 (10.25" DIA.)
3034	AFI GEAR BOX SUPPORT
BUL5151	NUT, M10 NY-LOCK, ZINC
BUL5163	BOLT, M10X35 ZINC
BUL5250	NUT, M14 ZINC
BUL5261	BOLT, M 14X30
BUL5261	BOLT, M14X30
BUL5896	BOLT, M14X40 FHSCS
BUL5952	WASHER, FLAT M10 ZINC
BUL5964	WASHER, M10 ALUMINUM
BUL5982	WASHER, M10 LOCK, ZINC
BUL5984	WASHER, M14 LOCK
BUL7002	NUT, IMPELLER LOCK 35X1.5
BUL7536	SCREW, SET M10 S.S.
GTP117	SEAL, RUBBER WASHER H150
GTP125	SEAL, WIDIA STATIONARY, AFI PUMP
GTP126	SEAL, WIDIA ROTATING, AFI PUMP
GTP127	O-RING, OIL FOR WIDIA SEAL HOLDER D.66, 35 S.2.62
GTP133	O-RING, AFI 35 GB41300
RAC102	PIPE CAP, ZINC 1/2"

Parts descriptions for AFI 24, 27, 35 Gearbox. Call your dealer for pricing.

E2011	AFI 24, 27, 35 GEARBOX PARTS VIEW
BUL5601	SCREW, M 8 X 16 SHCS
BUL6067	KEY 8X7X45MM AFI & VERT
BUL6072	KEY, 10 X 8 X 45
BUL7313	SNAP RING, S150-200 & AFI GEARBOX
BUL7567	SHIM, 45 X 65 X 1 (FORMERLY BUL7577)
BUL7576	SHIM, 65 X 80 (1 OF EACH BUL7564, BUL7565, BUL7566)
BUL7577	SHIM, 45 X 65 *USE BUL7567*
BUL7593	SHIM, D.95X110 0.160.7503.00 .28MM
BUL7594	SHIM, D.95X110 .42MM
BUL7595	SHIM, D.95X110 .49MM
BUL8201	WASHER, 8MM LOCK
CUS118	BEARING, 31310 J2/QCL7C
CUS137	BEARING, 6307
CUS142	BEARING, 3208 ATN9
CUS175	BEARING, 3307 ATN9 AFI GEARBOX
GRU105	GEARBOX , AFI 35 1:2.38 1000RPM/COMPLETE
GRU106	GEARBOX, AFI 27/35 1:3.35 1000RPM/COMPLETE
GRU107	GEARBOX, AFI 27/35 1:3.88 540 RPM/COMPLETE
GRU108	GEARBOX, AFI 27 1:4.93 COMPLETE
GRU109	GEARBOX, AFI 1:6.2 LONG SHAFT
GRU110	GEARBOX, AFI 1:6.2 SHORT SHAFT
GRU112	SHAFT, AFI35 PINION 1:1 2.38 21T 1000RPM
GRU113	SHAFT, AFI 27 19T 1:3.35 RATIO
GRU114	SHAFT, AFI 27-35 1:3.38 RATIO 17T 540RPM
GRU115	SHAFT, AFI 27 1:4.93 RATIO 14T
GRU116	GEAR PINION Z=10 FOR R. 1:6 WITH CHOPPER
GRU119	SHAFT, INPUT AFI GEARBOX
GRU121	GEAR AFI GEARBOX 50T 1:2.38
GRU122	GEAR, AFI GEARBOX 64T 1:3.35
GRU123	GEAR, AFI GEARBOX 66T 1:3.88
GRU124	GEAR, AFI GEARBOX 69T 1:4.93
GRU125	GEAR, AFI GEARBOX 62T 1:6.2
GRU127	OIL DIPSTICK
GRU128	COVER, REAR AFI GEAR BOX
GRU129	SEAL, GASKET AFI 27 & 35 - NO LONGER AVAILABLE, USE SILICONE INSTEAD
GRU176	COVER, AFI GEARBOX
GRU241	SHIM, 65X77X.4
GRU242	SHIM, 65X77X.3
GTP139	SEAL, OIL 50 72 10
GTP141	GASKET, GEARBOX BOTTOM COVER
GTP159	SEAL, OIL 35 X 80 X 10
GTP240	PLUG, FROST AFI GEAR BOX
GTP246	SEAL, WASHER AFI GEARBOX
PSC283	GEARBOX SHELL, AFI
RAC100	DRAIN PLUG



ADESCAMENTO DEPRESSORE AFI

Corpo Depre.
E2026

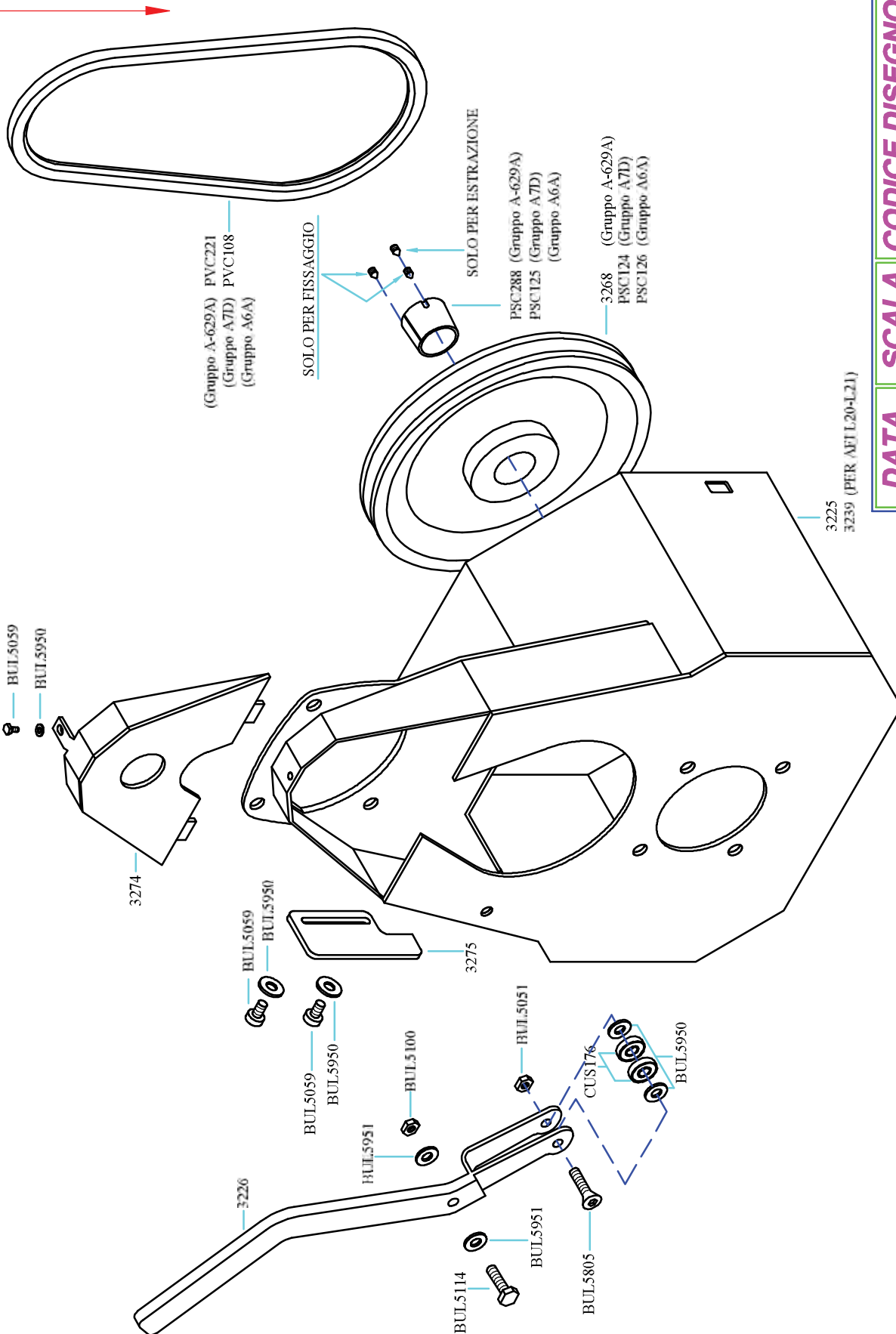

DATA	SCALA	CODICE DISEGNO
26/09/05		E2025

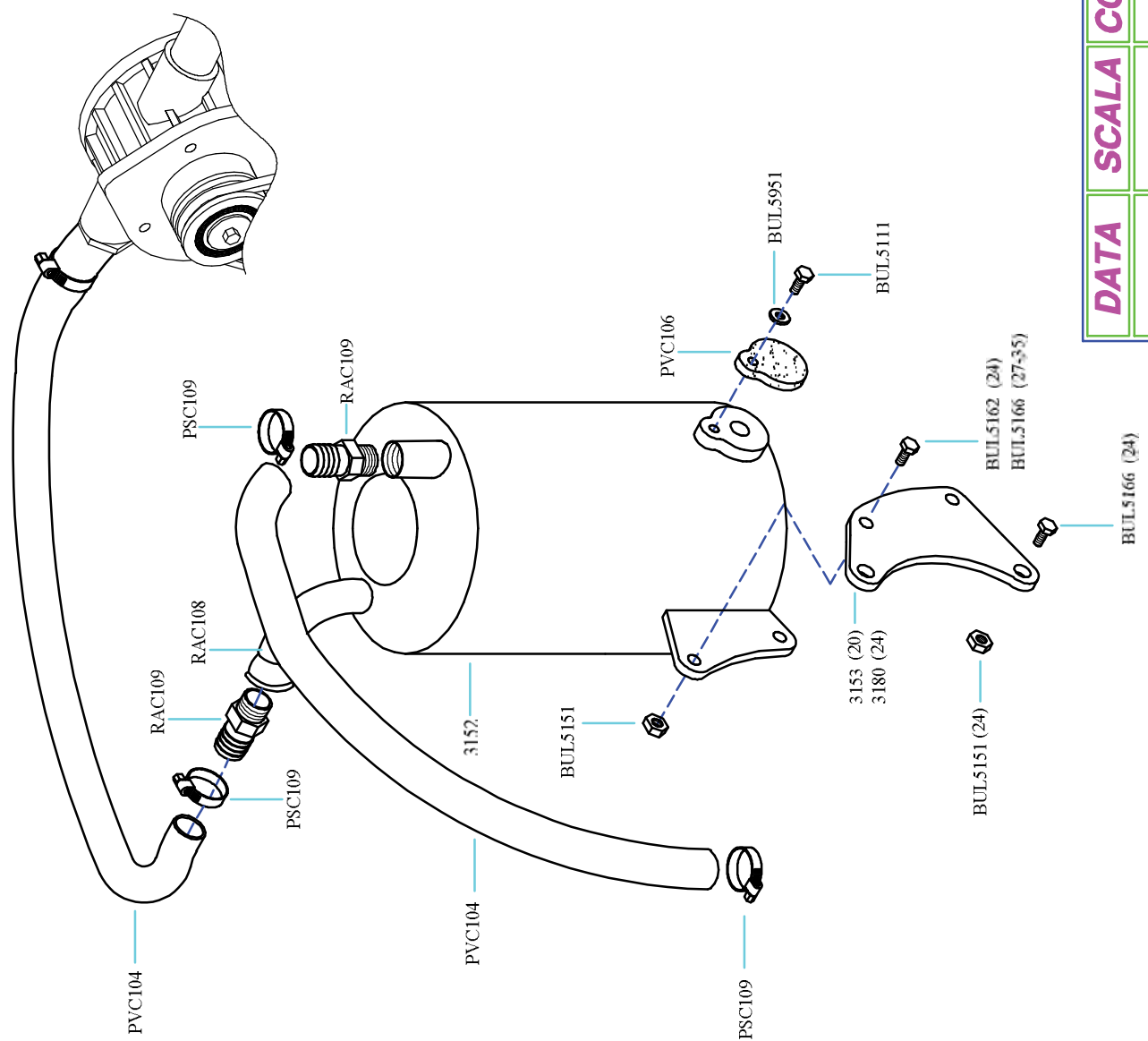

DATA	SCALA	CODICE DISEGNO
25/03/04		E2031



TAPPO CONO ASPIRAZIONE AFI

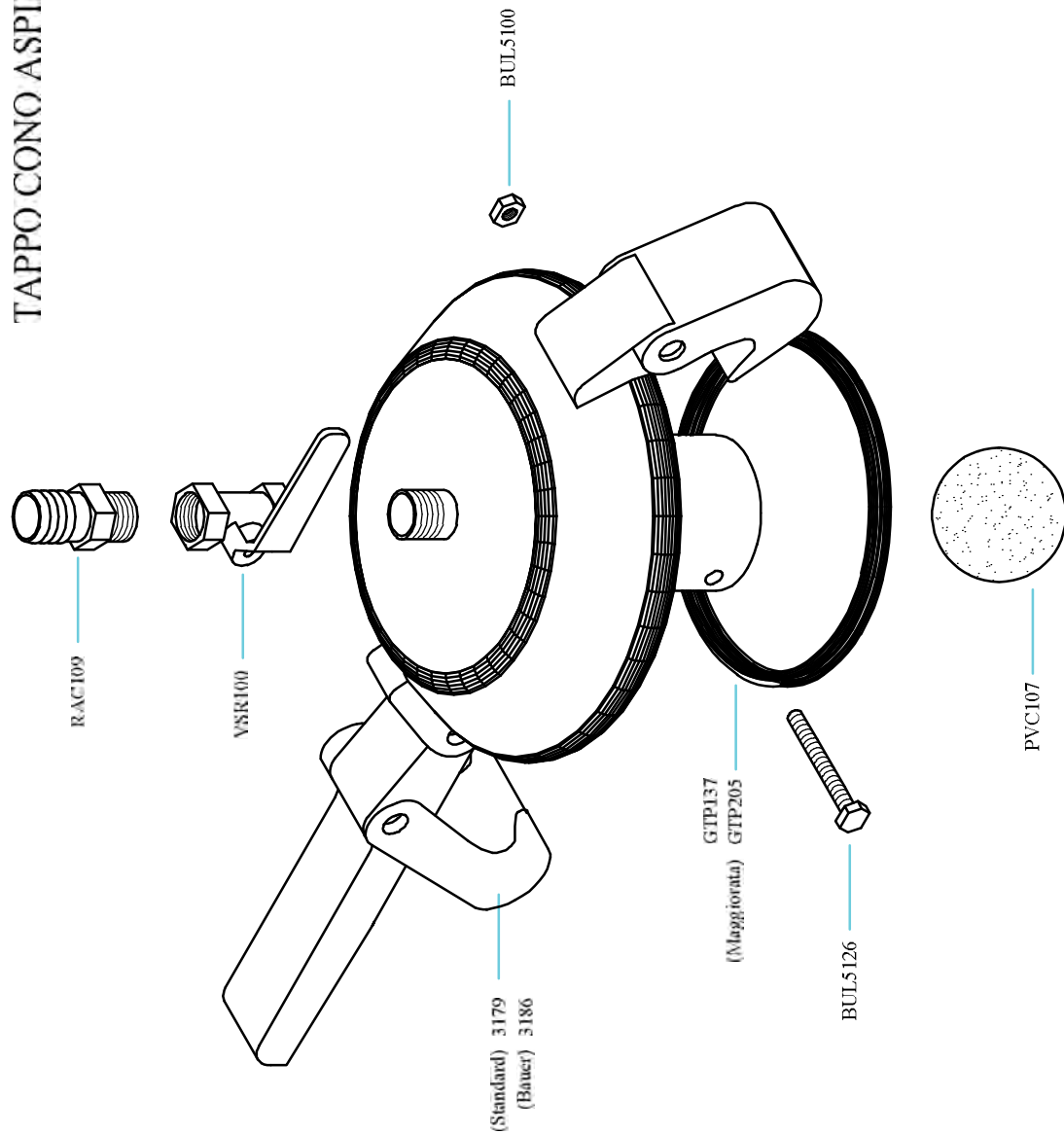

DATA	SCALA	CODICE DISEGNO
05/04/05		E2029



DEPRESSORE

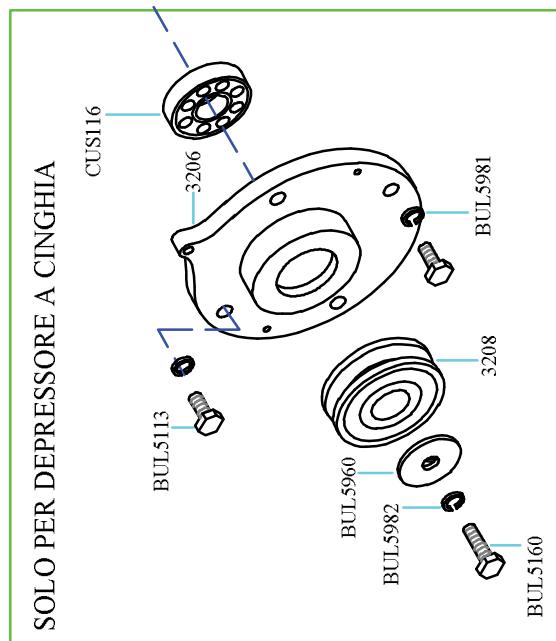
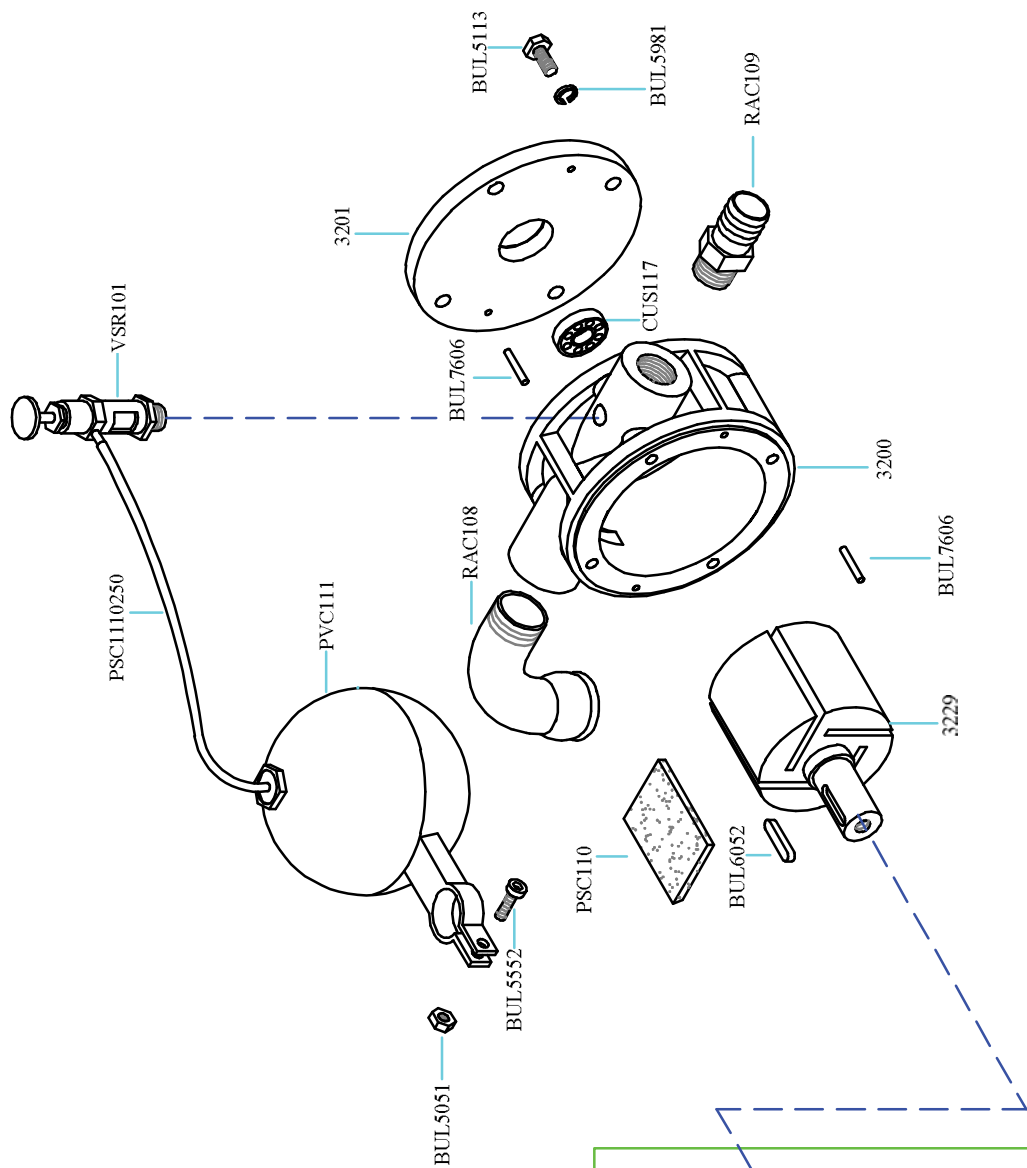

DATA	SCALA	CODICE DISEGNO
15/11/10		E2026

E2032	AFI CONE
3178	CONE, AFI SUCTION. NUDE-NO CLAPPER VALVE (O-RING WHERE CAP FITS STYLE)
3181	CONE, AFI SUCTION 150MM FERRARI
BUL5151	NUT, M 10 NY-LOCK ZINC
BUL5164	BOLT, M 10X 40 ZINC
E2032001	CONE, AFI 6" 150MM INTAKE 5" 120MM CAP, OLD STYLE COMPLETE. GALVANIZED
E2032002K	CONE, AFI FEMALE 6" 150MM CHIMNEY. COMPLETE. GALVANIZED
GTP 214	*USE GTP138* O-RING *USE GTP138*
GTP136	GASKET, RUBBER FOR AFI CONE (12 BOLT HOLE)
GTP138	O-RING, 6" 150MM FOR FEMALE COUPLING, FERRARI CONE
GTP205	O-RING, RUBBER 5" 120MM FOR AFI PRIMER CAP
GTP213	*USE GTP205* O-RING *USE GTP205*

E2028	CLAPPER VALVE FOR AFI CONE
3175	VALVE, FOR AFI CONE. RUBBER COATED
3176	HINGE FOR CLAPPER VALVE
3177	FRAME FOR CLAPPER VALVE. MOUNTS TO CONE
BUL5100	NUT, M 8 NUT-LOCK ZINC
BUL5113	BOLT, M 8 X 25 ZINC
BUL5152	NUT, M 10 STAINLESS
BUL5190	BOLT, M 10 X 70 STAINLESS
E2028	VALVE ASSEMBLY AFI CONE, INCLUDES CLAPPER, FRAME, HINGE, BOLTS, NUTS, O-RING
GTP135	O-RING FOR CLAPPER VALVE

E2025	AFI VACUUM PRIMER
3225	FRAME FOR VACUUM PRIMER, GALVANIZED WITH BELT, LESS VACUUM PUMP
3226	HANDLE FOR AFI VACUUM PRIMER
3268	PULLEY AFI HD 200/1A
3274	COVER FOR TOP OF VACUUM PRIMER FRAME, REMOVABLE
BUL5051	NUT, M 6 NY-LOCK STAINLESS
BUL5059	BOLT, M 6 X 10 SHCS ZINC
BUL5100	NUT, M 8 NY-LOCK ZINC
BUL5114	BOLT, M 8 X 30 ZINC
BUL5805	BOLT, M 6 X 25 FHSCS ZINC
BUL5950	WASHER, M 6 X 12 ZINC
BUL5951	WASHER, M 8 X 17 ZINC
CUS176	BEARING, 626 2RS
E2025002	PRIMER, AFI 24-35 FRAME W/VACUUM PUMP, HANDLE, BELT, ETC. LESS PULLEY
PSC124	PULLEY, LARGE 190/1A POWER PRIMER PTO DRIVE *REQUIRES PSC125 BUSHING*
PSC125	BUSHING, TAPERLOCK W/SET SCREWS FOR AFI PRIMER PULLEY
PSC126	PULLEY SMALL 160/1A FOR POWER PRIMER
PSC288	BUSHING, TAPERLOCK FOR AFI HD PRIMER
PVC108	BELT, AFI PRIMER A-37
PVC221	BELT, AFI HD PRIMER A-37.5

E2029	AFI SHUTOFF CAP
3179	CAP, AFI PRIMER CAP. NUDE (NOT BAUER)
BUL5100	NUT M 8 NY-LOCK ZINC
BUL5126	BOLT, M 8 X90 ZINC
E2029001	SHUTOFF CAP ASSEMBLY, NOT BAUER (O-RING IN CAP)
E2029003	SHUTOFF CAP ASSEMBLY, BAUER (O-RING IN CONE)
GTP137	O-RING 5" 120MM FOR FEMALE COUPLER/CAP
GTP205	O-RING 5" 120MM FOR FEMALE COUPLER/CAP (THICK)
PVC107	BALL, RUBBER 60MM FOR SHUTOFF CAP
RAC109	HOSE BARB 3/4" X 25MM NEW STYLE
VSR100	VALVE, BALL TYPE FOR SHUT OFF ON PRIMER CAP

E2031	AFI PRIMER CANISTER
3152	EXPANSION CAN ONLY FOR AFI PRIMER, NO HOSE BARBS, RUBBER FLAP, HOSES
BUL5111	BOLT, M 8 X 16 ZINC
BUL5151	NUT, M 10 NY-LOCK ZINC
BUL5162	BOLT, M 10 X 30 ZINC
BUL5166	BOLT, M 10 X 50 ZINC
BUL5951	WASHER, M 8 X 17 ZINC
E2031003	COMPLETE CAN FOR AFI PRIMER, WITH HOSE BARBS, HOSES, CLAMPS, RUBBER FLAP
PSC109	CLAMP, AFI PRIMER HOSES, 11/16" - 1 1/4"
PVC104	HOSE, SPIRAL 25MM CUT TO 27" LENGTH
PVC106	FLAP, RUBBER FOR EXPANSION CAN ON POWER PRIMER
RAC108	PIPE ELBOW, 90 DEGREE MALE 3/4" FEMALE 3/4" GALVANIZED
RAC109	HOSE BARB, 3/4" 25MM NEW STYLE

E2026	VACUUM PUMP FOR AFI PRIMER
3200	HOUSING, FOR AFI VACUUM PRIMER (E2026) (FUS102)
3201	COVER, FOR AFI VACUUM PRIMER (E2026) (FUS101)
3202	ROTOR, BRASS FOR VACUUM PRIMER *CANNOT BE SOLD ALONE*
3203	SHAFT FOR VACUUM PRIMER ROTOR *CANNOT BE SOLD ALONE*
3206	COVER, FOR AFI VACUUM PRIMER, HOLDS CUS116 (E2026) (FUS100)
3208	PULLEY, AFI POWER PRIMER
3229	ROTOR, BRASS PRIMER W/SHAFT *CANNOT BE SOLD ALONE*
BUL5051	NUT, M 6 NY-LOCK STAINLESS
BUL5113	BOLT, M 8 X 25 ZINC
BUL5113	BOLT, M 8 X 25 ZINC
BUL5160	BOLT, M 10 X 20 ZINC
BUL5552	BOLT, M 6 X 16 SHCS
BUL5981	WASHER, M 8 LOCK ZINC
BUL5981	WASHER, M 8 LOCK ZINC
BUL5982	WASHER, M 10 ZINC
BUL6052	KEY, 6X6X24MM C45K
BUL7601	PIN, PARALLEL D .4 X 28
BUL7606	PIN, PARALLEL D .4 X 22

Dealer Name: _____

Dealer #: _____

Purchase Date: _____

Pump Model: _____



*DODA USA INC.
255 16TH STREET SOUTH
ST. JAMES, MN 56081*

*p: 507.375.5577 admin@dodausa.com f: 507.375.5578
www.doda.com*
