

SERIES 70 MSD A.R. SLURRY INJECTOR OPERATING GUIDE

DSI, INC.

417 STATE ROUTE 117
GOODFIELD, IL. 61742
Phone: (309) 965-5110



CAUTION: Do not allow children or unqualified operators to operator equipment. In addition to design and configuration of equipment, safety and accident prevention are dependent upon the awareness, concern, and proper training of personnel involved in the operation, transport, maintenance, and storage of equipment.

OPERATION SECTION

Your new **Slurry Injectors** are designed to mount to a 4" x 6" tool bar and be spaced at 30", 36", or 38". We recommend the Slurry Injectors are spaced to operate **between** the previous year's crop rows and **not** on the rows. If Injectors are mounted less than 30" apart, it is recommended that the injectors are mounted offset fore and aft.

TOOL BAR HEIGHT

Tool bar height should be 30" at 6" sweep depth.

HORSEPOWER (PTO)

6-15 HP. PER SHANK

GROUND SPEED

MSD Slurry Shanks are designed to work best at speeds of 4 to 8 miles per hour. Higher speeds result in more surface soil disturbance. Do not exceed 8 miles per hour.

TILLAGE DEPTH

The Coulter is designed to operate up to 4" in depth while the Slurry Shank Point is designed to operate 5-6" deep. **RUNNING DEEPER THAN 6" WILL PLACE NUTRIENTS BELOW THE OPTIMUM LEVEL.**

MOUNTING THE SWEEP AND TUBE

If you hook a shelf rock, the lower sweep mount bolt (34) will shear to protect the shank (5).

The tube mount bolt (33) is also a tube pivot bolt. Tube mount nut (37) should be torqued lightly so that if the lower sweep mount bolt (34) shears, the slurry tube will pivot to prevent the hose from damage. Hose damage would occur if the hose was jammed against the rear of the shank (5).

Allowing the slurry hose to fall backward can cause plugging. Lightly torqueing the stover lock nut (37) on the slurry tube bolt (33) will keep the tube in the proper, vertical position preventing the hose from resting on the Dietrich Slurry Clozr, if in operation, and reduce slurry tube plugging.

NOTE: The Slurry Tube (31) is designed **not** to extend to the bottom of the sweep. Our tests have shown this Slurry Tube location allows slurry to flow down the opening created by the sweep. A longer Slurry Tube will cause more soil disruption.

SERIES 70 MSD SHANK ASSEMBLY

**CAUTION: DO NOT DISASSEMBLE
SPRING PACK**

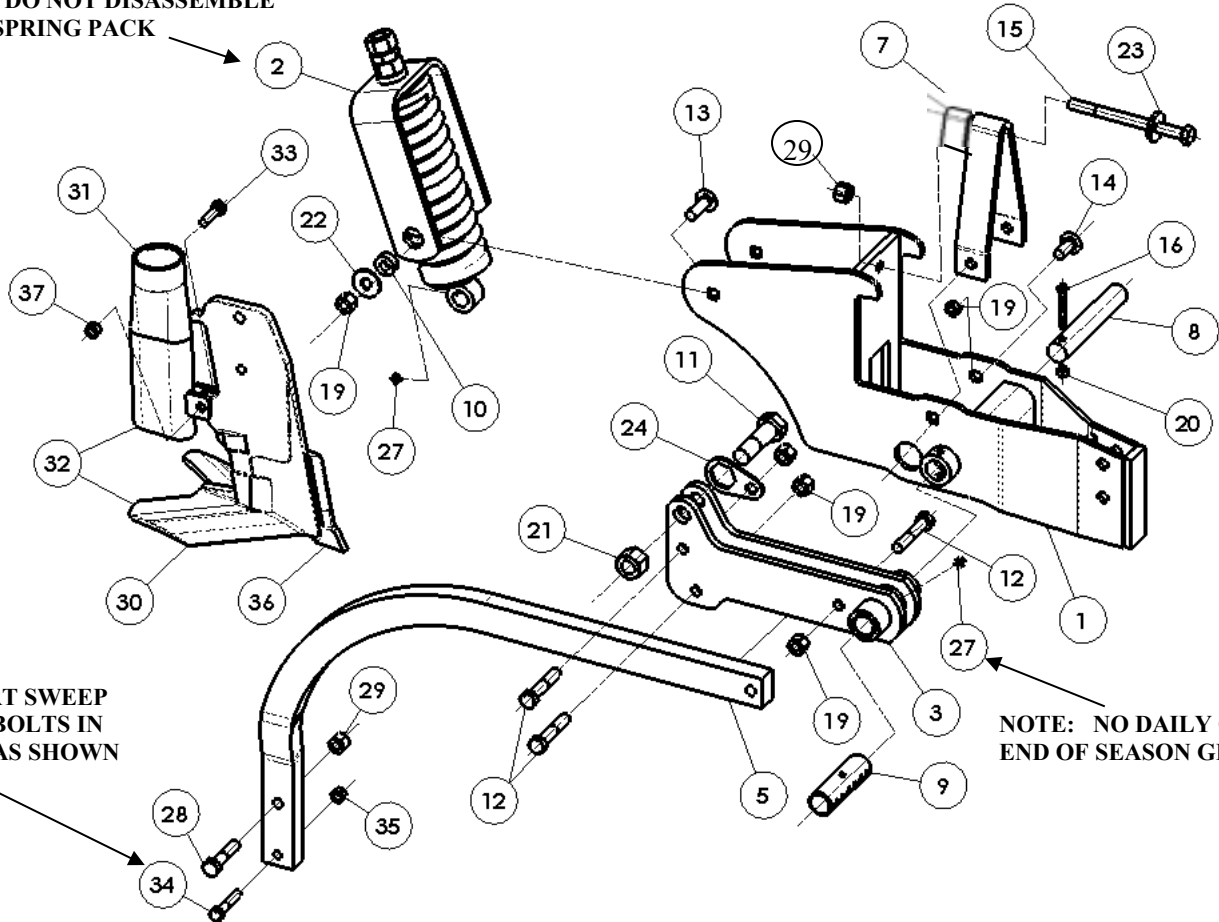

**NOTE: INSERT SWEEP
MOUNTING BOLTS IN
DIRECTION AS SHOWN**

**NOTE: NO DAILY GREASE.
END OF SEASON GREASING**

REF. NO.	PART NO.	NO. REQ.	DESCRIPTION	REF. NO.	PART NO.	NO. REQ.	DESCRIPTION
1	NSI	1	Shank Mount Weldment	24	5161150	1	Bolt Retainer – Earlier models
2	NSI	1	Spring Trunnion Assembly	27	NSI	2	1/8" NPT Self Tapping Grease Zerk
3	5130100	1	Shank Pivot Weldment	28	NSI	1	5/8" X 2-1/2" NC Hex Bolt Gd. 5 ZP
5	505010	1	Formed Shank	29	NSI	2	5/8" NC Nut ZP
7	5171101	1	Flip-up Bracket	30	SEE PAGE 3 FOR COMPLETE SWEEP OPTIONS		
8	5141100	1	Pivot Pin 1-1/4 Dia. heat treated	31	SEE PAGE 3 FOR COMPLETE TUBE OPTIONS		
9	44042500	1	Bushing- Earlier models	32	SEE PAGE 3 FOR COMPLETE SWEEP OPTIONS		
10	44006200	2	Bushing- Hardened				
11	16916145	1	1" Special Pivot Bolt				
12	16910135	3	5/8" Special Shank Bolt				
13	NSI	2	5/8" x 1-3/4" NC Carriage Bolt				
14	NSI	2	5/8" x 1-1/2" NC Carriage Bolt				
15	NSI	1	5/8" x 8" NC Hex Bolt, Gd 5 ZP				
16	NSI	1	7/16" x 2-1/2" NC Hex Bolt Gd 5 ZP				
19	NSI	7	5/8" NC Stover Lock Nut ZP				
20	NSI	1	7/16" NC Stover Lock Hex Nut	33	NSI	1	1/2" x 1-1/2" NC Hex Bolt, Gd 5 ZP
21	NSI	1	1" NC Stover Lock Nut	34	NSI	1	1/2" x 2-1/2" NC Hex Bolt, Gd 5 ZP
22	NSI	2	5/8" Washer	35	NSI	1	1/2" NC Hex Nut
23	17411012	1	1-3/4" OD x 11/16" ID x 1/4" Washer	36	502180	1	Chisel Tip Casting
				37	NSI	1	1/2" NC Stover Lock Hex Nut

NSI – NOT A SERVICE ITEM

SWEEP OPTIONS

Page 2 Ref

Series 70 Chisel Sweep Part Numbers

30	70800LC 8" Low Rate Chisel Sweep Less Tube
32	70822LC 8" Low Rate Chisel Sweep with Wing Drop Tube & Clip
32	70830LC 8" Low Rate Chisel Sweep with 3" Tube
32	70835LC 8" Low Rate Chisel Sweep with 3-1/2" Tube & Clip
32	70840LC 8" Low Rate Chisel Sweep with 4" Tube & Clip
30	70800HC 8" Hi Rate Chisel Sweep Less Tube
32	70822HC 8" Hi Rate Chisel Sweep with Wing Drop Tube & Clip
32	70830HC 8" Hi Rate Chisel Sweep with 3" Tube
32	70835HC 8" Hi Rate Chisel Sweep with 3-1/2" Tube & Clip
32	70840HC 8" Hi Rate Chisel Sweep with 4" Tube & Clip
30	71200HC 12" Hi Rate Chisel Sweep Less Tube
30	71200HCM 12" Max Lift Chisel Sweep Less Tube
32	71222HC 12" Hi Rate Chisel Sweep with Wing Drop Tube & Clip
32	71222HCM 12" Max Lift Chisel Sweep with Wing Drop Tube & Clip
32	71230HC 12" Hi Rate Chisel Sweep with 3" Tube
32	71230HCM 12" Max Lift Chisel Sweep with 3" Tube
32	71235HC 12" Hi Rate Chisel Sweep with 3-1/2" Tube & Clip
32	71235HCM 12" Max Lift Chisel Sweep with 3-1/2" Tube & Clip
32	71240HC 12" Hi Rate Chisel Sweep with 4" Tube & Clip
32	71240HCM 12" Max Lift Chisel Sweep with 4" Tube & Clip

Page 2 Ref

Slurry Tube Part Numbers

31	701122 Wing Drop Tube & Clip
31	730 3" Tube
31	735C 3-1/2" Tube & Clip
31	740C 4" Tube & Clip

Maximum Recommended Gallons Per Acre

- 8" Low Rate Sweep – 5,000 GPA
- 8" Hi Rate Sweep – 10,000 GPA
- 12" Hi Rate Sweep – 15,000 GPA
- 12" Max Lift Sweep – 20,000 GPA+



WARNING: *Blades have extremely sharp edges. Care must be taken when handling to avoid injury.

*Compressed springs have potentially dangerous stored energy. Always assemble and disassemble properly.

22" STANDARD COULTER ASSEMBLY OLDER MODELS ONLY

REF. NO.	PART NO.	NO. REQ.	DESCRIPTION
1	505100	1	Coulter Mount 22"
2	16516900	1	5/8" x 4" Snap Pin
4	505200	1	Coulter Arm with Hub
5	28063331	1	633 4-Bolt Hub and Spindle
6	5030015	2	Spring Holder Casting
7	2416560	1	Compression Spring
8	33502240	1	22" Coulter Blade- Smooth
9	505300	1	Coulter Pivot-DSI has ROUND corners on plate -DMI has SHARP corners
20	NSI	2	1-3/8" Machine Bushing – 14 Ga.
21	NSI	1	1-3/8" Machine Bushing – 10 Ga.
22	NSI	1	1/4" x 2" Cotter Pin
23	NSI	1	1/8" NPT Grease Zerk
24	S0000210	4	1/2" x 1-1/4" NF Hex Bolt Gd. 5
25	NSI	2	7/16" Roll Pin, ZP
26	17411012	2	11/16" I.D. x 1-3/4" O.D. x .25" Washer
27	16010629	1	5/8" x 15-1/2" NC Bolt Gd. 5
32	NSI	2	5/8" NC Hex Nut Gd. 5
33	505400	1	Coulter Arm Assy (Less Mount & Blade)

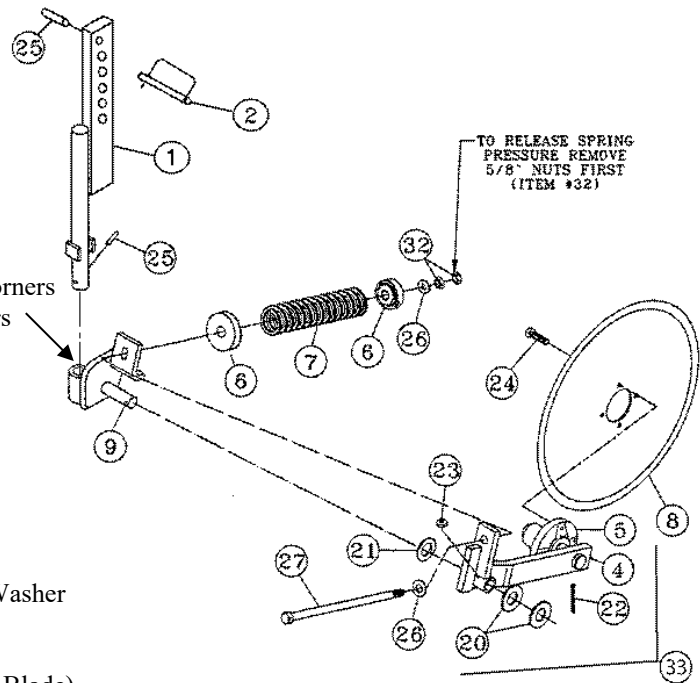

NSI- NOT A SERVICE ITEM

22" COULTER BLADE

Our coulter measures 22.6" in diameter. To wear our coulters to 20" diameter, wears 86 square inches of steel. To wear our competitor's 22" blade to 20", wears 66 square inches of steel. Our 22.6" blade will take 30% more acres to wear to a 20" diameter.

800# DOWN PRESSURE COULTER ASSEMBLY

REF. NO.	PART NO.	NO. REQ.	DESCRIPTION
1	504200	1	Coulter Pivot Weldment
2	504110	1	Coulter Arm with Hub
3	505100	1	Coulter Mount 22"
4	33502240	1	22" Coulter Blade
5	504120	1	T-Bolt Weldment
6	2416560	1	Compression Spring
7	503656	2	Spring Casting
8	NSI	4	1/2" x 1-1/4" NC Hex Bolt Gd. 5
9	16516900	1	5/8" x 4" Snap Pin
10	NSI	2	7/16" Roll Pin
11	NSI	2	1/4" x 2" Cotter Pin
12	NSI	1	1/8" NPT 90° Zerk – Coulter Arm Assy Pivot
	NSI	1	1/8" NPT Zerk – T-Bolt Spring Pivot, Grease Daily
	NSI	1	1/8" NPT Zerk – Vertical Coulter Pivot Sleeve, Grease Weekly (not visible in diagram)
13	NSI	1	1-3/8" x 10 Ga. Mach. Bushing
14	NSI	1	1-1/4" x 10 Ga. Mach. Bushing
15	NSI	1	1" NC Hex Nut
16	NSI	1	1" NC Hex Jam Nut
18	504210	1	1-3/8" x 5-5/8" Pivot Pin
19	NSI	1	7/16" x 2-1/2" NC Hex Bolt Gd. 5
20	NSI	1	7/16" NC Hex Nut
21	505800	1	Coulter Arm Assy (Less Mount & Blade)

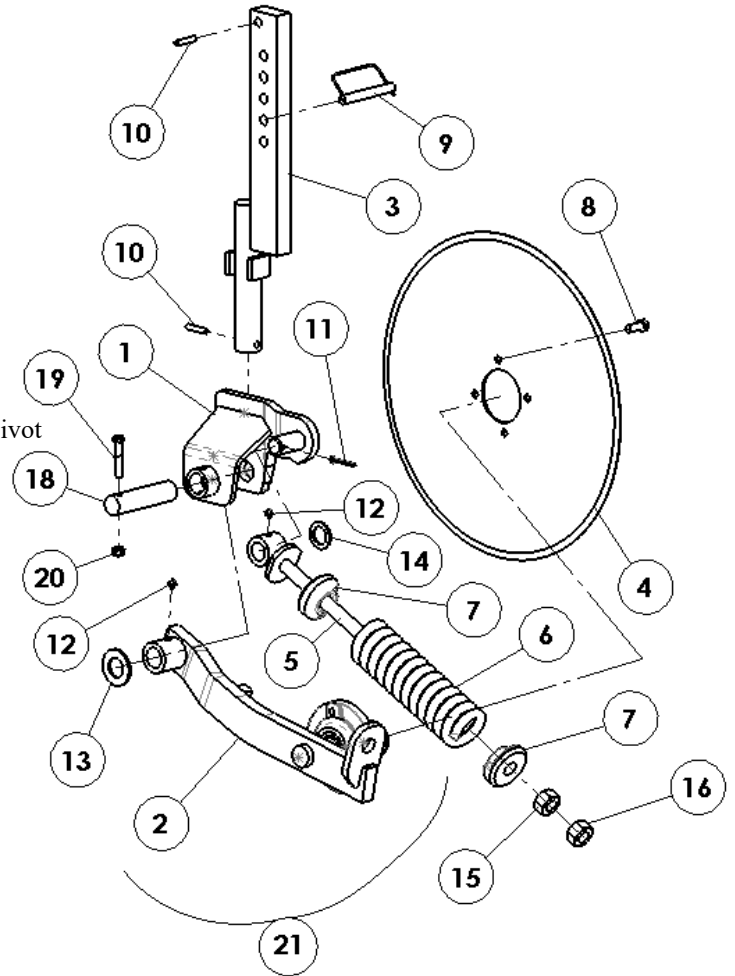

NSI- NOT A SERVICE ITEM

633 HUB ASSEMBLY

1	28063331	1	633 Hub and Spindle Assembly
2	28463300	1	Dust Cap
3	0750	1	.75" Bore Cone- Timken #LM11949
4	1780	1	1.78" OD Cup- Timken #LM11910
5	NSI	4	1/2" x 1-1/4" NC Hex Bolt Gd. 5
6	2330	1	2.33" OD Cup Timken #LM67010
7	1250	1	1.25" Bore Cone- Timken #LM67048
8	1501	1	1.50" ID x 2.33" OD Seal CR# 14975
9	NSI	1	5/32" x 1-1/2" Cotter Pin
10	NSI	1	3/4" NF Slotted Hex Nut
11	17413001	1	3/4" Special Washer
12	28363331	1	633 Spindle
13	28263340	1	Hub w/ Cups
14	504033	1	Dust Cap Retainer
15	504300	1	633 Spindle W/Cup Washer Weldment For 2017 & newer models

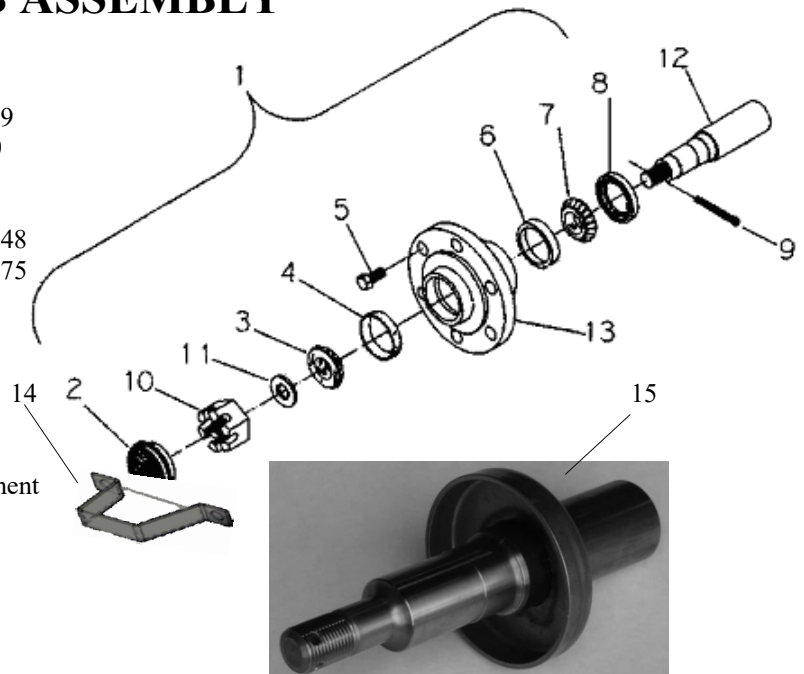

NSI- NOT A SERVICE ITEM

SERIES 70 SHANK MOUNTING ASSEMBLY

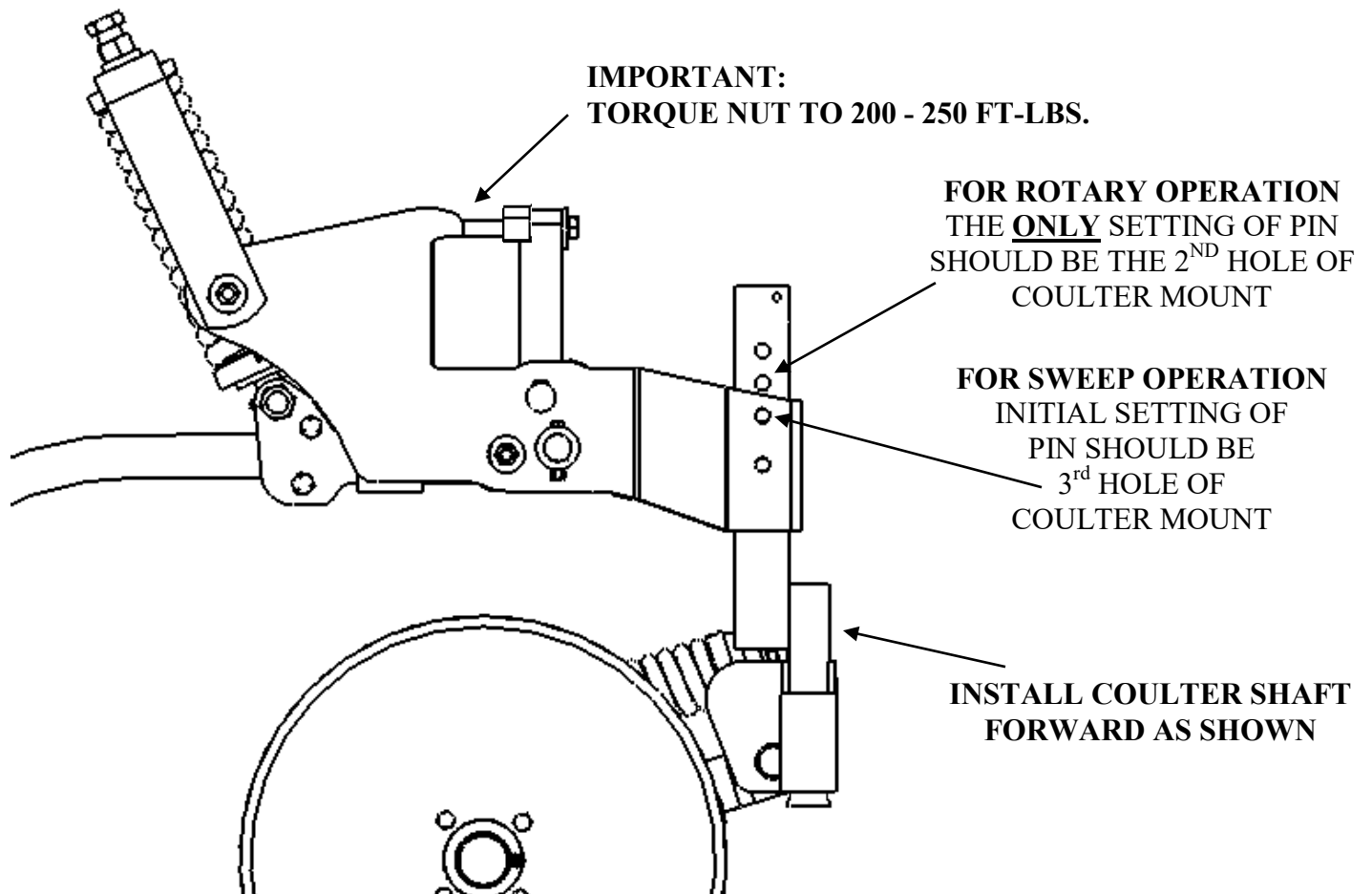

VERY IMPORTANT

THE DOWN FORCE ON THE COULER REDUCES AS COULER SPRING IS COMPRESSED. 800# COULER PEAKS AT APPROX. 900# WHEN COMPRESSION SPRING IS COMPRESSED AT 1/2". DOWN FORCE IS REDUCED TO 460# WHEN FULLY COMPRESSED. ADJUSTING COULER TOO DEEP WILL RESULT IN LESS CUTTING FORCE AND PLUGGING

Refer to Pages #2 of 9 and #3 of 9 for parts list

1. Rotate Flip-up Clamp to toolbar. Secure with 5/8" x 8" Hex Bolt (#15) and 5/8" Hex Nut (#29).

IMPORTANT: Retorque Hex Nut (#29 on page 2) to 200 - 250 FT/LBS, after **FOUR** hours of operation. Maximum allowable gap at the flip up bracket is 1/4"

2. Slide the Couler Arm Assembly (#1 on page 5) onto lower end of Couler Mounting Bar and secure with the 7/16 x 2-1/2" roll pin (#10 on page 5)
3. Slide the Couler Mounting Bar (#3 on page 5) up through the bottom of mounting bracket on the front of the Slurry Shank Assembly (#1 on page 2). Install Pivot Shaft forward as shown.
4. Slide the Couler Mounting Bar upward until the 3" dimension is obtained as shown in the above figure. (Use this only as a starting point for setting proper couler depth in the field). Insert Snap Pin (#9 on page 5)
5. Attach Couler Blade (#8 on page 5) to the Couler Arm Hub assembly.

TROUBLE SHOOTING FIELD PROBLEM REMEDIES

SERIES 70 MSD UNITS 8" WIDE SWEEPS

TO THE DIETRICH INJECTOR OWNER: DSI, INC. equipment is designed for tough conditions. Our products have innovative features that greatly improve performance and reduce operating costs if the product is used properly.

Improper use of these same features can result in excessive costs, premature failure, and poor field performance. The key to proper use is knowledge and awareness on your part. This section is designed to give you that awareness.

Engaging injectors into the soil before the tank & tractor are aligned causes tremendous side loading, especially on the outermost injectors. Unnecessary damage due to excessive side pressure is not covered under warranty.

POTENTIAL PROBLEM	PROBABLE CAUSES	REMEDIES
INSUFFICIENT SHANK DEPTH	Hard Soil Coulters adjusted too deep Front of honey wagon too low	Raise Coulters Raise Coulters Lower hitch casting to raise front of honey wagon.
SHANKS PLUGGING	Coulters adjusted too shallow Shanks not running between previous year's crop rows	Lower Coulters Switch to 25 Wave Conical Blades Adjust driving pattern to run Slurry Shanks between previous year's crop rows.
FURROW BEHIND SHANKS • For honey wagon • For drag lines	Shanks running on nose Front of tool bar too low	Adjust until the tool bar is level. Lengthen 3 rd link on 3-point hitch.
FIELD NOT SMOOTH ENOUGH TO PLANT NO-TIL	Driving too fast	Do not drive over 8 m.p.h. In some soil conditions, slower speed may be required.
BENT OR BROKEN COULTER MOUNT PARTS	Coulters adjusted too deep	Raise Coulters

OPTIONAL ATTACHMENTS

PIVOTING WING DROP TUBE FOR DIETRICH SWEEPS

Patent Applied For

Wing Drop Tube sits at a 10° angle

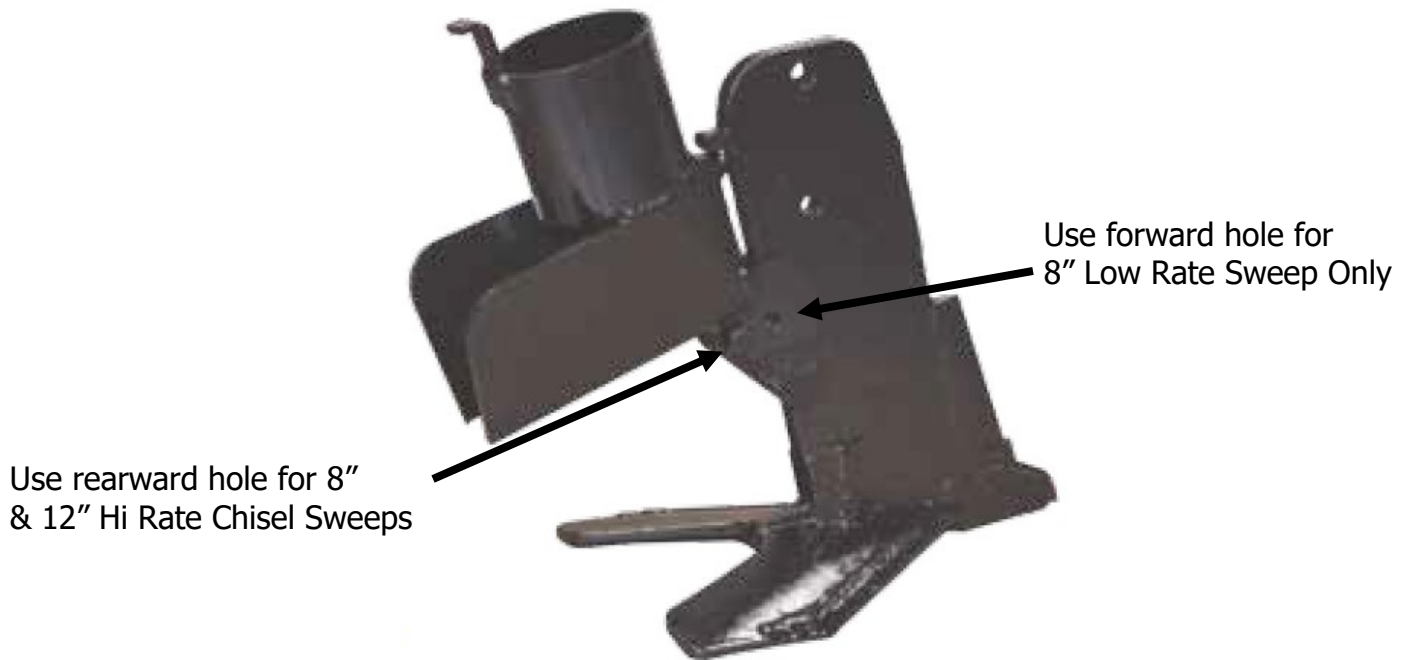

To prevent hose damage, do not torque the stover lock nut on the wing drop tube. Snug the stover lock nut so the unit can pivot when the bottom sweep bolt shears.

25 Wave Conical Blade

- Optional shallow form conical blade for sweep injecting in corn on corn conditions
- Clears a pathway ahead of the sweep

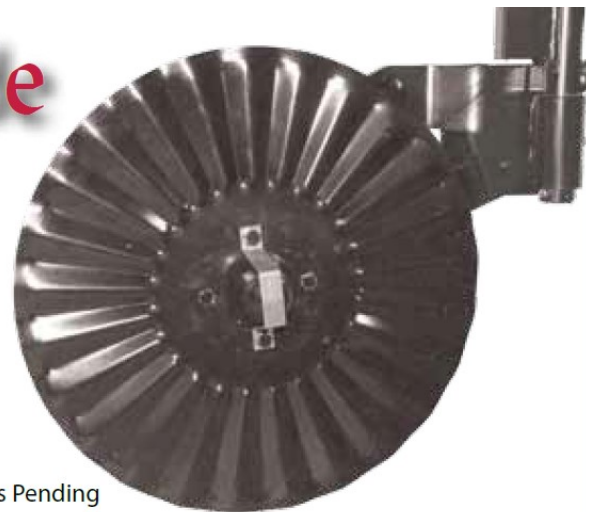

When properly installed, soil will be moved to the **LEFT** of the sweep when operated.



The Complete Dietrich Conical Blade/Sweep Injection System followed by the Dietrich Clozr includes:

Dietrich Series 70 Injector with 800# Down Pressure Coulters Assembly, 13 Wave Conical Blade, 4" Rotary Injection Discharge Tube & Bracket, your choice of Chisel Point Sweep & Discharge Tube, & the Dietrich Clozr with choice of Spherical or Flat Notched Blades.

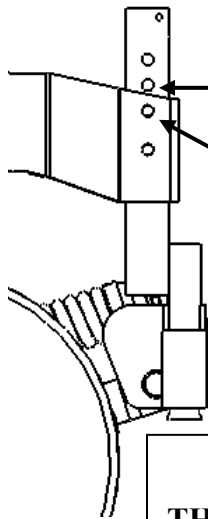

FOR ROTARY OPERATION
THE **ONLY** SETTING OF PIN SHOULD BE THE 2ND HOLE OF COULTER MOUNT

FOR SWEEP OPERATION
INITIAL SETTING OF PIN SHOULD BE 3RD HOLE OF COULTER MOUNT

VERY IMPORTANT

THE DOWN FORCE ON THE COULTER REDUCES AS COULTER SPRING IS COMPRESSED. 800# COULTER PEAKS AT APPROX. 900# WHEN COMPRESSION SPRING IS COMPRESSED AT ½". DOWN FORCE IS REDUCED TO 460# WHEN FULLY COMPRESSED. ADJUSTING COULTER TOO DEEP WILL RESULT IN LESS CUTTING FORCE AND PLUGGING

CHANGING BETWEEN SWEEP & ROTARY INJECTION OPERATION

If smooth Coulters Blade is attached, remove from Hub & install 13 Wave Conical Blade with concave or curved-in side against hub using the same hardware. When properly installed, soil will be moved to the **RIGHT** when operated.

The 4" Rotary Injection Tube & Bracket is designed to mount to the bottom hole of the curved shank with ½" bolt & nut. Using a 1-1/8" wrench on nut on the back of the Rotary Discharge Tube will allow for adjustment of your slurry hose.

Mount the Dietrich Slurry Clozr according to instructions in the Dietrich Slurry Clozr Operating Guide. Notice the suggested settings for Clozr & front Coulters Blade.